

HONDA ENGINES

T-E-GXV340 - GX Series Commercial Grade

HONDA® E N G I N E S



Features

- Honda 11HP OHV engine
- Cast iron cylinder sleeve
- Commercial-grade
- Easy starting, fuel efficient
- Spin-on Oil filter
- EPA/CARB compliant

Note: *Horsepower rating shown as maximum power output is in accordance with SAE J1940. Actual engine power will be lower. Engine power depends on accessories, operating speeds, operating conditions and other variables.

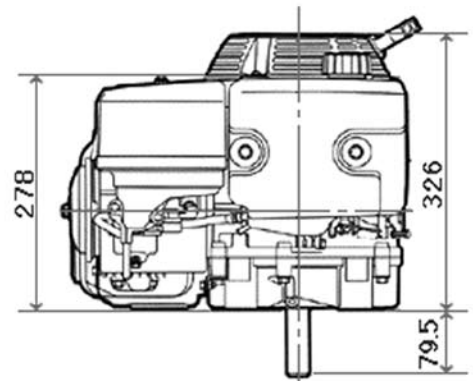
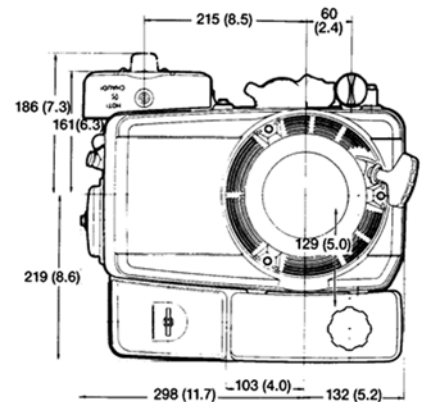
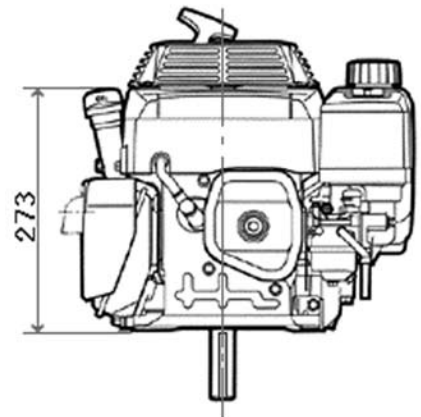

Specifications

Horsepower**	11		
Type	K2		
Variation	DA33	DE33	DAP2(2)
Oil Alert®	•		
Crankshaft P.T.O.	3 1/8 x 1 dia. tapped 7/16 20 UNF		
Top Speed Governed Speed - No Load	3600		
Recoil Starter	•		
12V Starter		•	(2)
Transistor Ignition	•		
Air Cleaner	DE		
Fuel Tank (QT)	W/O	2.2	W/O
Net Weight	72 lbs	78 lbs	72 lbs

NOTES:

Some notes may not be applicable for this model.

(1) 12V (AC)-50w.lamp coil (2) 10 amp charging
SD Semi dry, OB Oil bath, DE Dual Element, CY Cyclone

*These models can also be ordered with inner-vent carburetors.